

Railway and MetroRail – Finding and solving AC and DC power problems

From Jerusalem Light Rail to the Hong Kong Subway, from Silicon Valley California to Belgium, rugged little PQube®3 monitors have become the first choice for recording power disturbances.

PQube®3 – A power monitor specifically configured for railway use!

Every PQube®3 automatically adapts to 16.667 Hz, 50 Hz, 60 Hz, and 400 Hz – and DC too, **up to 1200 volts**. And every PQube®3 automatically sends you an email with detailed graphs and reports in your own language: **no software required**. Just look in your inbox!

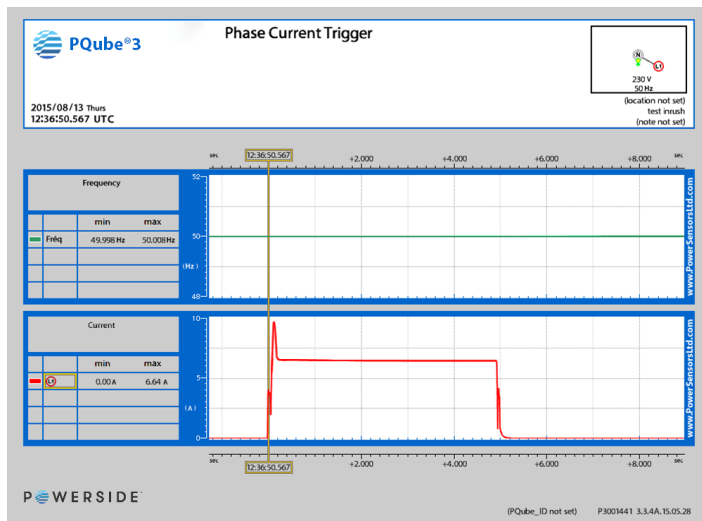

Electromechanical point switching – predicting failures with your PQube®3’s AC current signatures

What could you do with the signatures of the current flowing into the motors that drive your electromechanical (or electro-pneumatic) switches? Well, your PQube®3 has 8 standard current channels, and each one can trigger on the current inrush caused by the motor start. You’ll get a graph (and an Excel® file) with the detailed before-and-after current signature. A large inrush current indicates trouble starting the motor – check the bearings for wear. And if the signature shows that current flows through the motor for a few seconds longer than usual, you probably have a mechanical failure developing. **You can actually predict failures before they happen!**



AC-DC rectifiers, transformer overheating, unbalance, and harmonic currents

Every PQube®3 includes the full IEC suite of harmonic measurements, and both IEEE and IEC unbalance measurements – it’s perfect for transformer/rectifier monitoring. When utility power transformers overheat, it can be difficult to determine if you have a temporary overload problem, or a harmonics current problem, or perhaps an intermittent current unbalance problem. **You’ll diagnose all of these problems easily with your PQube®3 from the comfort of your office, even if the problems come and go.**

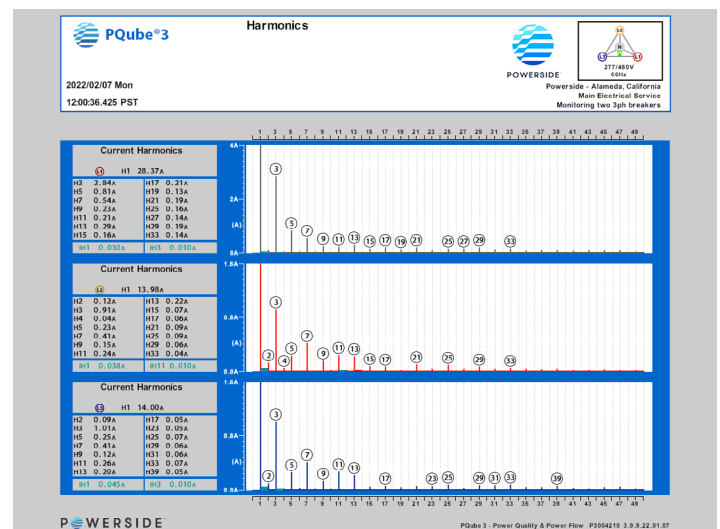

Detects every kind of power disturbance – AC and DC

You can easily set your PQube®3 to trigger on sags/dips and swells, but you can also trigger on current inrush, current threshold, Rapid Voltage Change, frequency, and even High Frequency Impulses in **as fast as one microsecond**. Your PQube® comes with a detailed NIST-Trace Certificate, guaranteeing that there will be no questions about its better-than-0.1% accuracy. It's fully UL-listed, CE-marked, and Certified – and made in the USA.

Sometimes you need to monitor a 600-volt or 1kV DC bus – no problem, the PQube®3 is designed for this. You'll get cross-

triggered disturbance recordings showing you oscilloscope waveforms, simultaneously, on your AC supply and your DC bus. And you'll get power readings on both sides so you can quickly see rectifier efficiency, and predict rectifier failures.

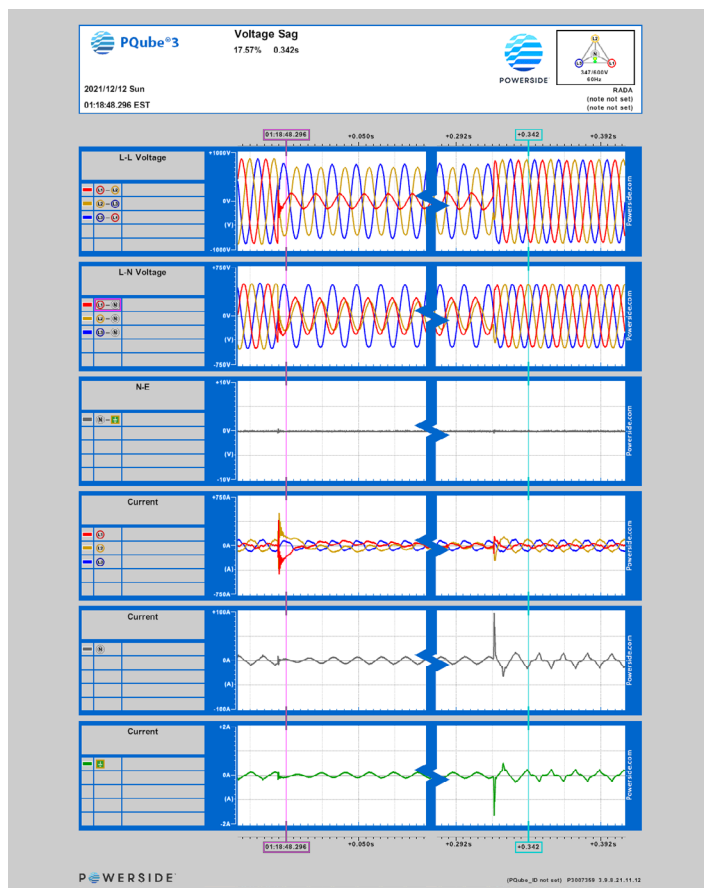
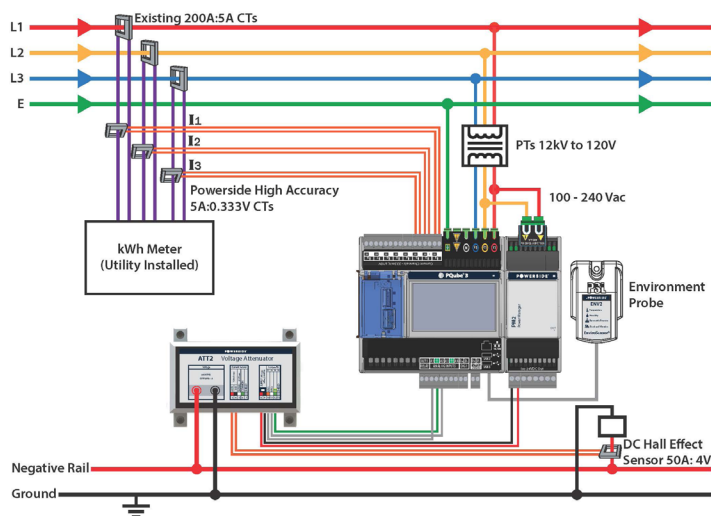

Earth current monitoring – why does it trip?

Sometimes a powerful AC monitoring instrument isn't enough. Fortunately, your standard PQube®3 can also monitor four DC channels, too! It can even monitor DC current, including difficult-to-solve transient DC earth currents when trains enter or leave the station. **Place a PQube®3 monitor at troublesome stations, and wait for your emails to arrive.** You'll figure out what's happening in no time.

Intermittent control & communication failures – could it be power disturbances?

Nothing is more frustrating than trying to diagnose intermittent control failures. If you can't reproduce them, how can you fix them? Well, you can simplify the problem by using PQube®3s to monitor the AC voltage, and DC supplies, inside your controls. You'll find out if you have power disturbances, you'll learn exactly what they are so you can choose the correct solution, and – if you don't have power disturbances – your PQube®3 will document how clean your power is with its daily trends-and-statistics reports – **no software required**.





Escalators – dangerous sudden stops, caused by voltage sags

When escalators (moving stairs) stop abruptly, passengers can be hurt. One fairly common cause is that the Variable Frequency Drive that operates the escalator shut off due to a voltage sag. To defend yourself, you need documented factual data from PQube®3: exactly when did the sag happen, how deep was it, and how long did it last? You can even use this information to budget for increasing escalator immunity to voltage sags.

Remote graphing and more than 1,000 meters – all free!

Every PQube®3 instrument implements more than 1,000 different ModBus meters – everything from simple voltage, current, and frequency to temperature, humidity, barometric pressure (use it to detect air flow failure in underground tunnels!), and even X-Y-Z mechanical acceleration. Powerside provides a free, easy-to-use Modbus program for your Windows PC. You can also use the built-in website inside every PQube®3.

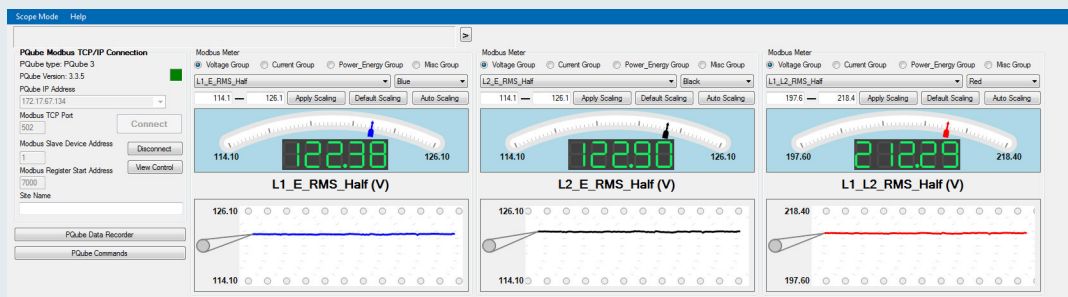

Easy to install – train cabin, control panel, rectifier

Your PQube®3 mounts on any standard 35mm DIN-rail, or you can purchase an indoor or outdoor enclosure. And your PQube®3 is fully Certified almost everywhere in the world, making installation completely worry-free.

Check out <https://powerside.com/products/monitoring/pqube-3-power-analyzers/> for more information.



Contact Us

United States

980 Atlantic Ave
Alameda (CA) 94501
1-888-736-4347

Canada

7850 Trans-Canada Highway
Saint-Laurent (QC) H4T 1A5
1-877-333-8392

sales@powerside.com
powerside.com

